

LABORATORY ASSESSMENT OF THE ELECTRO-OSMOTIC CONSOLIDATION TECHNIQUE FOR URMIA LAKE SEDIMENTS^{*}

K. BADV^{1**} AND K. MOHAMMADZADEH²

^{1,2}Dept. of Civil Engineering, Urmia University, Urmia, I. R. Iran
Email: k.badv@urmia.ac.ir

Abstract– The electro-osmotic consolidation is a method to improve geotechnical properties of soft clayey soils. The feasibility of electro-osmotically induced consolidation can be examined through the soil coefficient of electro-osmotic permeability (k_e) and the electro-osmotic coefficient of water transport (k_i). Using an electro-osmotic testing cell, k_e and k_i parameters were measured in Urmia Lake west coast sediments. Three electric field intensities of 40, 60 and 80 V/m were used and salinity and pH change was monitored in cathode and anode reservoirs during the tests. k_e and k_i increased when soil void ratio increased. The results showed that increasing applied electric field intensity increased the rate of water pH and salinity change at cathode reservoir. The results for soil hydraulic conductivity (k_h) and k_e showed that k_h is in the range of 10^{-10} m/s to 10^{-9} m/s for the range of void ratios between 0.5 to 0.8, respectively, and k_e is in the range of 5.5×10^{-9} to 6.6×10^{-9} m²/s/V for the range of void ratios between 0.72 to 0.83, respectively. The ratio of k_e/k_h controls electro-osmotically induced negative pore water pressure. The higher the ratio, the higher the pore water pressure difference and the faster the consolidation is. The range of k_e/k_h was between 5.2 to 9.4 m/V at the void ratios between 0.83 and 0.72, respectively. The ratio of k_e/k_h increased when void ratio decreased. The high range of k_e/k_h proved the effectiveness of electro-osmosis consolidation for the Urmia Lake sediments.

Keywords– Electro-osmotic consolidation, Urmia Lake sediments, electro-osmotic permeability, hydraulic conductivity

1. INTRODUCTION

Soil improvement in fine-grained soils involves techniques that are implemented to increase strength properties, decrease compressibility and deformation and accelerate dewatering and consolidation processes [1-13]. Recent developments in the offshore oil and gas industry have resulted in an increasing number of offshore platforms being erected. Land reclamation is now practiced in many coastal parts of the world to cope with increasing demands for land [14]. There exist practical and economical needs to accelerate dewatering and consolidation of sediments and mine tailings, for long term storage or landfilling [6, 15-24]. Furthermore, electro-osmosis techniques have been implemented to remediate contaminated lands [25-27]. For these reasons, geotechnical and geo-environmental engineers need to search for innovative and practical soil improvement techniques to revise and optimize traditional soil improvement methods. This work answers the call by investigating some parameters that influence the electro-osmotic treatment.

When a DC field is applied in a soil-water-electrolyte system, three electro-kinetic transport mechanisms for water, ions and soil solids are identified, i.e. electro-osmosis, electro-migration and electrophoresis [28-31]. Electro-osmosis is the movement of soil pore fluid, electro-migration is the

^{*}Received by the editors July 11, 2014; Accepted May 6, 2015.

^{**}Corresponding author

movement of ions in the soil pore fluid and electrophoresis is the movement or tendency of movement of soil solids.

This paper evaluates the feasibility of electro-osmotic consolidation of Urmia Lake west coast sediments through the measurement of the coefficient of electro-osmotic permeability (k_e) and electro-osmotic coefficient of water transport (k_i) using an electro-osmosis apparatus.

2. THEORY

In 1949 Leo Casagrande introduced the electro-kinetic treatment of soil to improve its geotechnical properties [28]. Since then, electrokinetic treatment has been successfully applied to increase the strength of sensitive deposits [1, 2, 32], transport stabilizing agents into the pores of a weakly cemented soil [33] and dewater and consolidate mine tailings, sediments and marine deposits [6, 15, 17, 22, 24, 34, 35]. However, electrokinetic treatment in field applications has been limited by many uncertainties regarding the influencing parameters in the process (e.g. electrode material, applied voltage, current intermittence, void ratio and pore fluid salinity), questions about the effectiveness of the technique to generate the desired results, the economic viability of the method, and the long term effect of the treatment.

The movement of water under the influence of the electric field is attributed to its drag by the mobile counter ions in the electrical double layer. The electro-osmosis flow has been described by various theories including Hemholtz-Smoluchowski model, Schmidt theory, Spiegler friction model, ion hydration, and Gary-Mitchell approach [36]. The Hemholtz-Smoluchowski model is widely accepted by geotechnical engineers to explain the phenomenon of electro-osmosis in soils. In the model, the coefficient of electro-osmotic permeability, k_e (m^2/sV) is expressed as [31]:

$$k_e = -\frac{\zeta \epsilon n}{\mu} \quad (1)$$

where $\zeta(V)$ is the zeta potential (negative in clayey soils), ϵ (F/m) is the permittivity of the fluid, μ (Ns/m^2) is the viscosity of the pore fluid, and n is the porosity of soil.

The economic viability of electro-osmotic method could be evaluated through the determination of the quantity of water transported in applied unit electric current $I(A)$ through the soil. The coefficient of electro-osmosis water transport k_i (L^3/C , i.e. volume of transported water per unit electric charge, C) is written by the following equations:

$$k_i = \frac{qA}{I} \quad (2)$$

$$qA = k_i I = k_e i_e A \quad (3)$$

$$k_i = \frac{k_e i_e A}{I} = \frac{k_e i_e}{j} = \frac{k_e}{\lambda} \quad (4)$$

where q is the quantity of water transported per unit area of soil, A is the total cross sectional area of soil (m^2), I is the applied electric current (A), i_e is the electric field intensity (V/m), j is the density of electric current (A/m^2), and λ is the bulk electric conductance of the soil (S/m).

During enhanced electro-osmosis consolidation, negative pore water pressure is developed within the soil which causes the increase of effective stress and consolidation of the soil. The negative pore water pressure is a function of the ratio of k_e/k_h and the electric voltage $V(x)$ as follows [37]:

$$u(x) = -\frac{k_e}{k_h} \gamma_w V(x) \quad (5)$$

where k_h is the soil hydraulic conductivity, γ_w is the unit weight of water, and x is the distance from cathode reservoir. The higher the ratio of k_e/k_h , the more negative the pore water pressure developed in the soil is and hence, the more effective the electro-osmosis consolidation will be.

3. ELECTRO-OSMOSIS APPARATUS

The electro-osmosis (EO) apparatus used for the laboratory EO experiments is the modification of the apparatus used by Micic [5] and Mohamedelhasan [3]. The schematic of the apparatus is depicted in Fig. 1. The apparatus consisted of an EO-cell, loading equipment, an electrical circuit, a DC power supply, control/instrumentation devices, and volume measurement devices. The apparatus has been designed with the following practical considerations: (1) the loading equipment can simulate the in situ stress condition, generate a remoulded soil sample with the required void ratio, and combine electro-osmosis and preloading consolidation; (2) the vertical electrode setup is readily implemented in the EO-cell to allow for replacement of corroded electrodes; (3) the soil sample is of adequate size to allow for the study of geotechnical properties after an electro-osmosis test; (4) the cell is insulated from leakage and electric conduction; (5) the drainage condition can be adjusted to suit the required boundary conditions; (6) the applied electric field is approximately one-dimensional; and (7) the voltage distribution, electrical current, and water flow in the soil sample can be measured at any time during testing without power interruption.

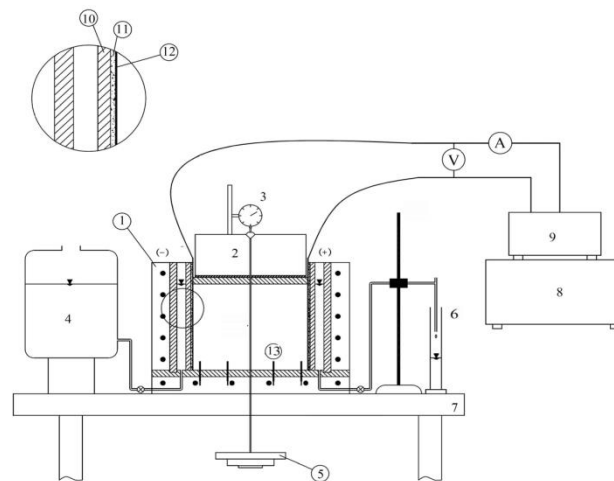

1- EO testing cell, 2- loading plate, 3- dial gauge, 4- water supply tank, 5- surcharge, 6- graduated cylinder, 7- base table, 8- DC power supply, 9- timer, 10- perforated Plexiglas plate, 11- copper electrode, 12- geotextile filter, 13- voltage probe

Fig. 1. Schematic of the electro-osmosis test apparatus

The EO testing cell is a rectangular tank made of 15 mm thick Plexiglas plates, with the outside dimensions of 430 mm long, 130 mm wide, and 305 mm deep. The inside dimensions (the soil compartment) are 250 mm long, 100 mm wide, and 250 mm deep. The EO-cell weights about 8.5 kg. A specially designed loading plate equipped with a dial gauge was placed on the top of the soil specimen to apply a surcharge through the dead weights. The dial gauge was used to measure the settlement of the soil. The base plate of the EO-cell was equipped with two drainage valves at the ends of the cell to allow for drainage of expelled water from the soil during treatment. Therefore, drainage from the soil sample could be controlled at either end of the sample. Geotextile filters were placed at both sides of the soil sample, i.e., behind the cathode and anode to prevent loss of soil through the drainage channel. Expelled water to the cathode reservoir was collected in the graduated cylinder beside the cell, as shown in Fig. 1.

Two electrodes were used to generate an electric field in the soil sample via a DC power supply, as shown in Fig. 1. The electrodes were made of 1 mm thick copper mesh with 8.5 mm nominal openings. The horizontal spacing between the electrodes was 250 mm. This arrangement generates an approximately uniform horizontal electric field in the soil sample. A voltage was applied by a DC power supply with a maximum capacity of 3.5 A and 35 V. The power supply was connected in series with an automatic control switcher (timer) for current intermittence and an ammeter and in parallel with a voltmeter. The voltage distribution across the sample was measured by four voltage probes which were fastened onto the bottom of the cell as shown in Fig. 1. The probes were inserted about 30 mm into the soil and connected to a voltmeter to measure the voltage distribution across the soil sample.

4. MATERIALS AND METHODS

a) Physical and chemical testing on soil samples

The Urmia Lake is the second largest salt lake of the world in the northwest of Iran. The site in which the soils samples were taken is located in the west coast of the Urmia Lake with a distance of 23 Km east of Urmia City, Iran. The geotechnical investigations conducted on the site have revealed that the soil deposits up to 14 meters deep mainly consist of alternate layers of soft clayey and silty deposits (CL-ML, CL and ML) with occasional sand lenses in between the fine grained layers [38]. The soil samples were recovered from 1 – 1.5 m deep in the ground surface and were collected in plastic bags to retain the natural moisture content.

The soil mechanical tests were performed on the collected soil samples to identify the soil major geotechnical (physical) properties. The soil pH and salinity and the bulk soil and the pore water electric resistivity were determined as part of the soil chemical properties. Table 1 summarizes the soil physical and chemical properties.

Table 1. Soil physical and chemical properties

Property	Magnitude	Property	Magnitude
Liquid limit (%)	27	Percent sand	23
Plastic limit (%)	29	Percent silt	59
Unified soil classification	CL-ML	Percent clay	18
Specific gravity	2.67	pH	8.3
Range of natural water content (%)	28-30	Salinity (g/L)	2
Optimum water content (%)	16	Bulk soil electrical	
Maximum dry unit weight (kN/m ³)	17.2	resistivity (S/m)	0.115
Bulk unit weight (kN/m ³)	20	Soil pore water electrical	
		resistivity (S/m)	0.375

The consolidation tests were performed on the soil samples to determine the soil consolidation properties. Figure 2 shows the $\log(\sigma'_v)$ - e curve and Table 2 shows the consolidation parameters obtained for the tested soil sample. In Table 2, a_v , m_v and C_v refer to the coefficient of compressibility, the coefficient of volume change, and the coefficient of consolidation, respectively. The compression index (C_c) of 0.238 and the recompression index (C_r) of 0.018 were obtained from Fig. 2.

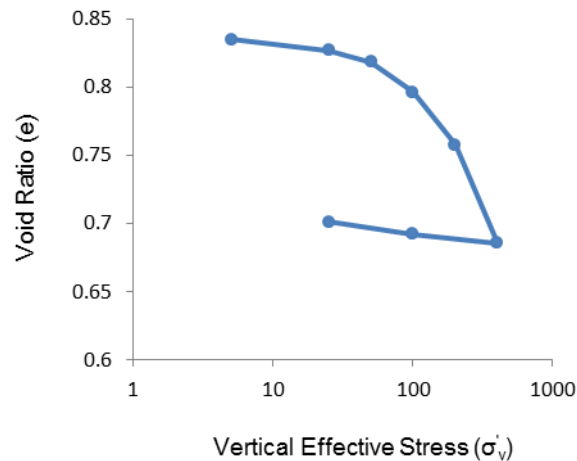

Fig. 2. Consolidation curve for the tested soil sample

Table 2. Consolidation parameters for the tested soil

σ_v (kN/m ²)	e_o	e_f	a_v $\times 10^{-7}$ (m ² /N)	m_v $\times 10^{-7}$ (m ² /N)	c_v $\times 10^{-7}$ (m ² /N)
25	0.84	0.83	4.6	2.5	6.1
50	0.83	0.82	4.5	2.5	4.9
100	0.82	0.80	4.4	2.4	3.9
200	0.80	0.76	3.9	2.1	3.6
400	0.76	0.68	3.5	2.0	3.2

b) EO testing program and methodology

Twelve electro-osmosis tests were performed on the soil samples under different test conditions. Four different surcharges of 10 kPa, 15 kPa, 20 kPa, and 30 kPa were applied on the soil. The electric voltages of 10V, 15V, and 20V were used for any EO test under a prescribed surcharge. The selection of 4 surcharges of 10, 15, 20 and 30 kPa in the EO tests was based on the approximate heights of 0.5 m, 0.8 m, 1.0 m and 1.5 m road embankment constructed on the Urmia Lake west coast sediments, the place where the soil samples were taken. The selection of the voltages was based on the data reported in the literature for similar soils [4]. Each EO test was repeated once to ensure the reproducibility of the test results and similar results were obtained for duplicated tests. Application of each surcharge caused the soil samples to have different void ratios at the start of the EO test. During each EO test, the electro-osmosis flow volume (q), change in electric field (E) and electric current (I), and change in pH and salinity were measured.

The EO testing methodology is described as follows: the soil sample was installed in the soil compartment of the EO cell and its height was measured. The loading plate was installed on top of the soil, the surcharge was applied and the sample was allowed to consolidate under the applied surcharge. Depending on the applied surcharge, 95% of consolidation occurred between 10 and 20 days. At the end of consolidation, the settlement and final height of the soil was determined. After consolidation of the soil sample, the water levels in the cathode and anode reservoirs were adjusted at the surface of the soil. The electric system was turned on and the electro-osmosis test commenced. The EO test elapsed for about 8 hours and during the test, the volume of infiltrated water towards the cathode within a prescribed time span was measured, the electric potential between two electrodes and within the soil was measured, and samples were collected from the cathode and anode reservoirs for pH and salinity measurements. At the end of each EO test, the weight, the dimensions, and the water content of the tested soil were measured and the unit weight and void ratio of the soil sample was calculated.

c) Hydraulic conductivity tests

As described earlier, the ratio of k_e/k_h controls the electro-osmotic pore pressure. The higher the ratio, the higher the electro-osmotically induced negative pore water pressure and faster the soil electro-osmosis consolidation [37]. The soil hydraulic conductivity was measured with triaxial hydraulic conductivity apparatus under 15 kPa, 20 kPa, and 25 kPa effective stresses and K_h of 1.8×10^{-10} m/s, 1.4×10^{-10} m/s, and 1.0×10^{-10} m/s was obtained, respectively.

5. RESULTS AND DISCUSSION

As described earlier, 12 EO tests were performed to fully investigate the viability of the electro-osmosis method on the Urmia Lake west coast sediments. At the end of each EO test, the following graphs were plotted: (1) the volume of collected water in the cathode reservoir against the elapsed test time and against the time within which the electric current was applied (two plots), (2) the change in electric voltage against distance from anode within the soil sample, (3) magnitude of pH in cathode and anode reservoirs against elapsed time, (4) magnitude of salinity of cathode and anode reservoirs against elapsed time, and (5) electric conductance in the cathode and anode reservoirs against elapsed time.

To allow for the brevity of the text, only plots for EO test under 15 kPa surcharge are shown as follows. The initial water content and unit weight of the soil sample was 35% and 18.4 kN/m³, respectively. After consolidation under 15 kPa surcharge, the water content and unit weight of the soil sample was 28.5% and 19.2 kN/m³, respectively. Decrease of the soil water content and increase of the soil unit weight are the obvious effects of the soil consolidation under 15 kPa applied surcharge. The pH, salinity, and electric conductance of the soil pore water was 8.3, 1.9 gr/L, and 0.376 S/m, respectively. Three electric potentials of 10 V, 15 V, and 20 V were used between the two electrodes. Figures 3a and 3b show the change in volume of the collected water in the cathode reservoir against the elapsed time of the test and time within which the electric potential is applied (for three electric potentials), respectively. As shown in Figs. 3a and 3b, by increasing the elapsed test time and time within which the electric potential is applied, the volume of collected water in the cathode reservoir increased. As described earlier, when the electric field was applied to the soil, cations responded to move in the direction of the electric field while anions moved in the direction opposite the electric field. The double layer accounts for the fact that there must be more cations than anions to achieve neutrality and thus net momentums were imparted on the water molecules by cations and caused them to migrate toward the cathode reservoir. The longer the applied electric field, the more the water moved towards the cathode reservoir. There is a direct relationship between the intensity of the electric potential and the amount of migrated water towards the cathode. As shown in Figs. 3a and 3b, when the electric potential was increased, more water was collected at the cathode reservoir.

Figure 4 shows the change in electric voltage against distance from anode within the soil sample for three electric potentials. As shown in Fig. 4, when distance from anode increases, the electric voltage decreases. Also, when the electric potential increased, the electric voltage gradient (i_e , see Table 3) across the soil increased which resulted in more water being dragged towards the cathode reservoir.

Table 3. Results of EO test on the soil sample with 15 kPa consolidation pressure

V (V)	I (A)	A (cm ²)	E (V/m)	i_e (V/m)	λ (S/m)	q (ml/h)	k_i (m ³ /C)	k_E (m ² /s.V)	k_e (m ² /s.V)
10	0.10	227.5	40	33.4	0.131	14.8	4.1×10^{-8}	4.6×10^{-9}	5.4×10^{-9}
15	0.16	227.5	60	52.8	0.114	25.5	4.4×10^{-8}	5.2×10^{-9}	6.0×10^{-9}
20	0.21	227.5	80	74.0	0.113	39.0	5.1×10^{-8}	5.9×10^{-9}	6.4×10^{-9}

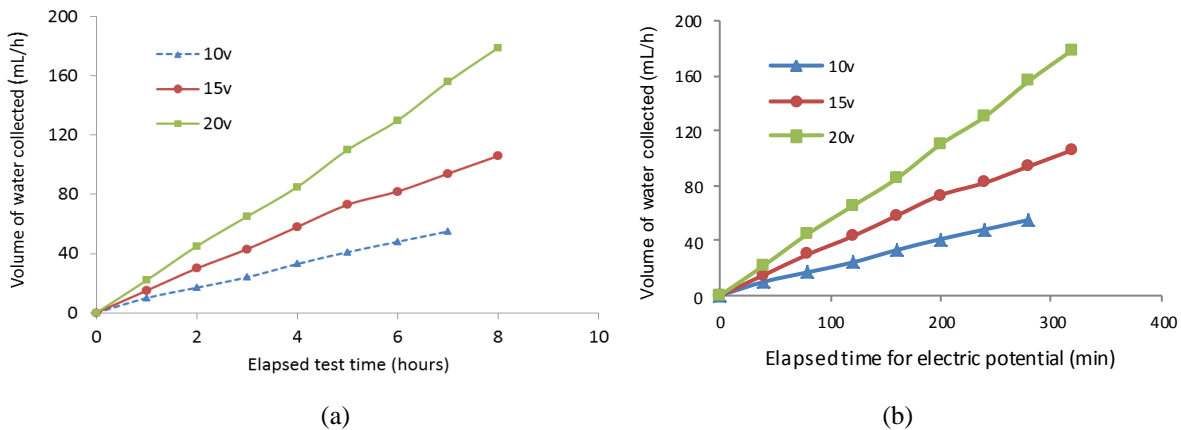

Fig. 3. Volume of water collected in cathode reservoir against: (a) elapsed test time, (b) elapsed time for electric potential, for 10V, 15V, and 20V electric potentials in EO test under 15 kPa surcharge

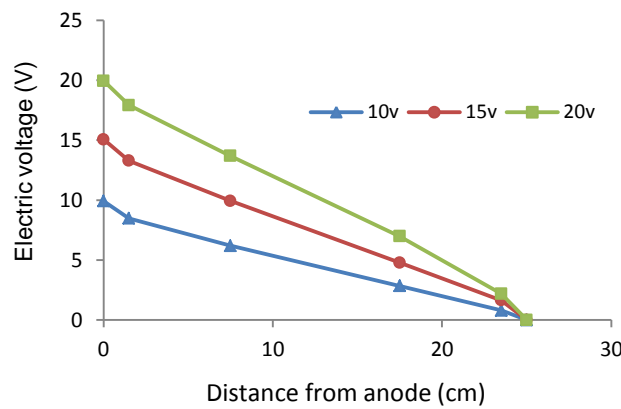

Fig. 4 Electric voltage against distance from anode for 10V, 15V, and 20V electric potentials

As described earlier, at the beginning of the EO test, the pH of solutions in both cathode and anode reservoirs was 8.3. Figure 5 shows the change in pH values in cathode reservoir (solid curves) and anode reservoir (dashed curves) against the test elapsed time. As shown in the figure, the permeation of soil water from anode to cathode due to electro-osmosis caused the pH of solution in the cathode reservoir to increase and in the anode reservoir to decrease with test elapsed time. The electric potentials in the cathode reservoir were 10V (lower solid curve), 15V (middle solid curve), and 20V (upper solid curve) while in the anode reservoir this was kept at 10V (three lower dashed curves).

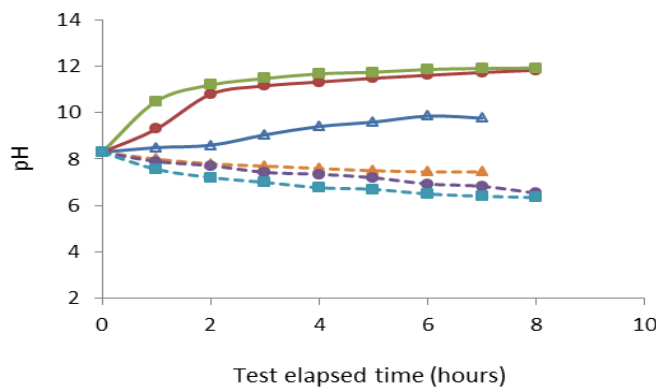

Fig. 5. pH of cathode reservoir (3 upper curves) and anode reservoir (3 lower curves) against test elapsed time in EO test under 15 kPa surcharge

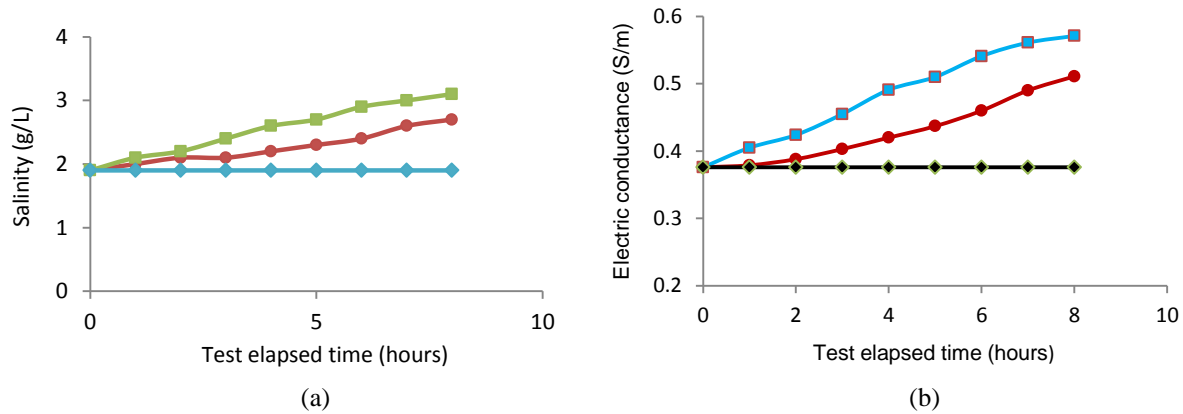

Fig. 6. (a) Salinity, (b) Electric conductance, in the cathode and anode reservoirs against test elapsed time in EO test under 15 kPa surcharge

Figure 6a shows the change in salinity of solutions in cathode and anode reservoirs against the test elapsed time. In the figure, the upper curve represents cathode reservoir in 20V test, the middle curve represents cathode reservoir in 15V test, and the lower curve represents the anode reservoir. As shown in Fig. 6a, the salinity of solution in cathode reservoir increased with time while the salinity of solution in anode reservoir remained constant.

Fig. 6b shows the change in electric conductance of solutions in cathode and anode reservoirs against the test elapsed time. In the figure, the upper curve represents cathode reservoir in 20V test, the middle curve represents cathode reservoir in 15V test, and the lower curve represents the anode reservoir. As shown in the figure, the electric conductance of solution in cathode reservoir increased with time while in the anode reservoir it remained constant.

When the electric field was applied to the soil, at the anode, water was oxidized releasing oxygen and creating protons (H^+) resulting in an acid front moving towards the cathode. This caused the pH, salinity, and electric conductance at the cathode reservoir to increase with time. The higher pH increased the water movement through the soil towards the cathode reservoir. At the cathode, hydrogen evolved and a base front of hydroxyl ions (OH^-) was generated and moved towards the anode.

Table 3 summarizes the results of EO test on the soil sample with 15 kPa consolidation pressure. In the table, E is the intensity of electric field between two electrodes (V/m), and k_E is the coefficient of electro-osmosis permeability for a given electric field intensity (E). The other parameters in the table are as described earlier.

Figures 7a and 7b show the relationship between the coefficients of electro-osmosis permeability (k_e) and electro-osmosis water transport (k_i) with the void ratio of tested soil, respectively, for three electric field intensities. As shown in the figures, the general trend is that by increasing the soil void ratio, the k_e and k_i values increase.

The ratio of k_e/k_h was calculated for three electric field intensities and for the range of soil void ratios and are summarized in Table 4 and plotted in Fig. 8. As shown in Table 4 and Fig. 8, the ratio of k_e/k_h is in the range of 5.2 to 9.4 m/V and it increased when the sediments void ratio decreased. As described earlier, the development of the negative pore water pressure due to electro-osmosis, is a function of the ratio of k_e/k_h and the electric voltage $V(x)$. Hence, the higher range of the k_e/k_h in the conducted electro-osmosis tests on the Urmia Lake sediments, is an indication of the development of high negative pore water pressure, resulting in high effective stresses and hence, enhanced consolidation. This could be considered as the economic viability of the electro-osmosis consolidation technique for the Urmia Lake sediments in the laboratory scale.

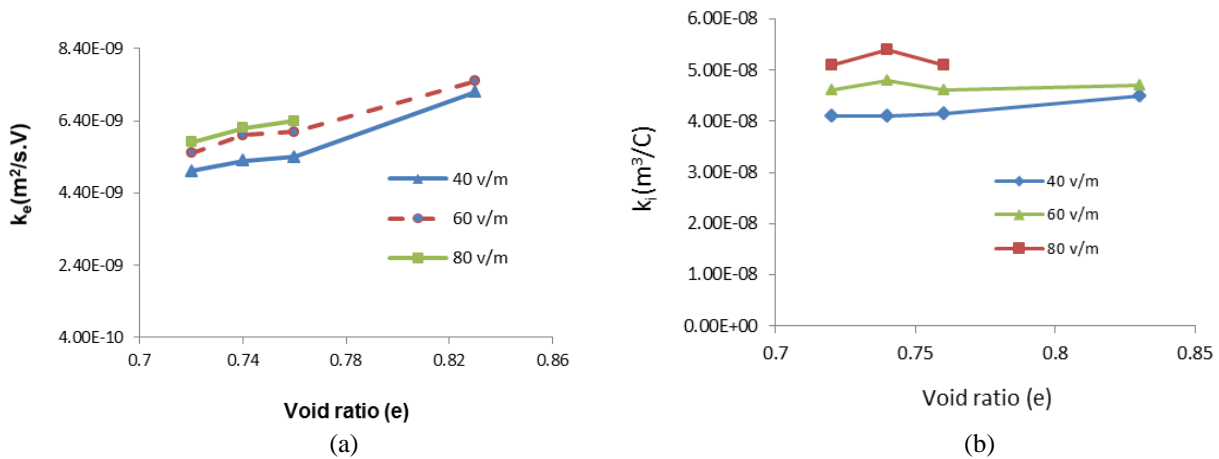

Fig. 7. (a) The coefficient of electro-osmosis permeability (k_e), (b) The coefficient of electro-osmosis water transport (k_i), against soil void ratio for three electric field intensities (E) in EO test under 15 kPa surcharge

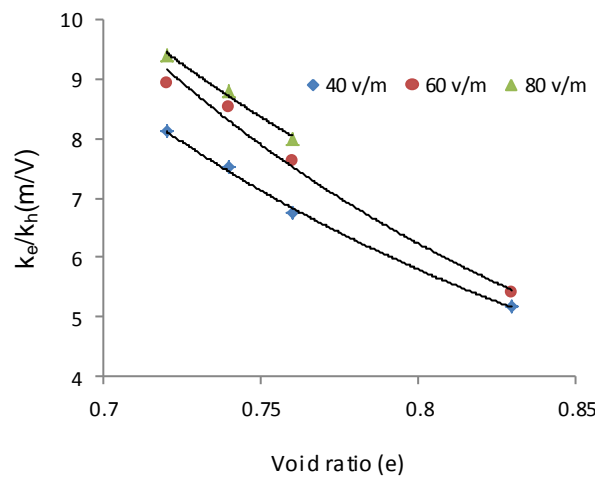

Fig. 8. The ratio of k_e/k_h against soil void ratio for three electric field intensities (E) in EO test under 15 kPa surcharge

Table 4. k_e/k_h values (m/V) against the soil void ratios in three electric filed intensities

Void ratio	Electric filed intensity, E (V/m)		
	40	60	80
0.72	8.1	8.9	9.4
0.74	7.5	8.9	8.8
0.76	6.8	7.6	8.0
0.83	5.2	5.4	NA

6. SUMMARY AND CONCLUSIONS

The feasibility of electro-osmotic technique was evaluated in the sediments of Urmia Lake west coast by laboratory tests. An electro-osmosis test apparatus was fabricated to determine the key parameters including the coefficient of electro-osmosis permeability (k_e) and electro-osmosis coefficient of water transport (k_i). Prior to the EO tests, the soil samples were consolidated at 10 kPa, 15 kPa, and 20 kPa surcharges. Then, EO tests were conducted under three electric field intensities of 40 V/m, 60 V/m, and 80 V/m and k_e and k_i parameters were determined. Using triaxial hydraulic conductivity apparatus, the hydraulic conductivity of the soil samples was determined and the ratio of k_e/k_h was calculated to

investigate the effectiveness of the electro-osmosis technique in consolidation of the tested sediments. The following conclusions were made from this experimental study:

- (1) The results showed that the coefficient of electro-osmosis permeability (k_e) at the electric field intensities of 40 V/m, 60 V/m, and 80 V/m and for the range of soil void ratios of 0.72 to 0.83, is in the range of $5.0 \times 10^{-9} \text{ m}^2/\text{s.V}$ to $6.6 \times 10^{-9} \text{ m}^2/\text{s.V}$ with the average value of $5.9 \times 10^{-9} \text{ m}^2/\text{s.V}$.
- (2) The coefficient of electro-osmosis permeability increased when the soil void ratio increased.
- (3) The average electro-osmosis coefficient of water transport (k_i) for the tested Urmia Lake sediments is $4.5 \times 10^{-8} \text{ m}^3/\text{C}$ and its magnitude increased when the intensity of electric field and the soil void ratio increased.
- (4) The sediments hydraulic conductivity was measured with triaxial hydraulic conductivity apparatus under 15 kPa, 20 kPa, and 25 kPa effective stresses and K_h values of $1.8 \times 10^{-10} \text{ m/s}$, $1.4 \times 10^{-10} \text{ m/s}$, and $1.0 \times 10^{-10} \text{ m/s}$ were obtained, respectively
- (5) For the range of tested electric field intensities and sediments void ratios, the ratio of k_e/k_h was in the range of 5.2 to 9.4 m/V. This high range of k_e/k_h proved the effectiveness of the enhanced electro-osmosis consolidation technique for the Urmia Lake sediments. The magnitude of k_e/k_h increased when the sediments void ratio decreased.

Acknowledgments: This paper forms part of a research program in geoenvironmental engineering being conducted at the Environmental Geotechnique Research Laboratory at the Department of Civil Engineering in Urmia University, Iran. The funding for this research was made possible by the award of a research grant to K. Badv from Urmia University of Iran.

REFERENCES

1. Lo, K.Y., Ho, K.S. & Incullet, I. I. (1991a). Electro-osmotic strengthening of soft sensitive clay. *Canadian Geotechnical Journal*, Vol. 28, No. 1, pp. 62-73.
2. Lo, K.Y., Ho, K. S. & Incullet, I. I. (1991b). Field test of electro-osmotic strengthening of soft sensitive clay. *Canadian Geotechnical Journal*, Vol. 28, No. 1, pp. 74-83.
3. Mohamedelhassan, E. E. (2002). Soil improvement using electrokinetic and vacuum technique. *Ph.D. Thesis*, Department of Civil and Environmental Engineering, The University of Western Ontario, London, Canada, p. 226.
4. Mohamedelhassan, E. E. (2009). Electrokinetic strengthening of soft clay. *Ground Improvement*, Vol. 162, No. 4, pp. 157-166.
5. Micic, S. (2002). Electro-kinetic improvement of offshore foundations. *Ph.D. Thesis*, Department of Civil and Environmental Engineering, The University of Western Ontario, London, Canada, p. 276.
6. Lockhart, N. C. (1981). Sedimentation and electro-osmotic dewatering of coal washer slimes. *Fuel*, Vol. 01.6 0, pp. 919-923.
7. Mok, C. K. (2006). Design and modelling of electro-osmotic dewatering. *Ph.D. Thesis*, School of Civil Engineering and Geosciences, University of Newcastle upon Tyne, Australia, p. 160.
8. Marshall, O., Grey, C. E., Malone, P. & Weiss, C. (2010). Moisture control using intelligent single well electro-osmotic dewatering systems. *U.S. Army Engineer Research and Development Center (ERDC) and Construction Engineering Research Laboratory (CERL)*, U.S.A, OMB No. 0704-0188, p. 27.
9. Mckinney, J. P. (2010). Design of electrolytic dewatering systems for phosphatic clay suspensions. *Ph.D. Thesis*, Department of Chemical Engineering, University of Florida, U.S.A., p. 103.
10. Yang, L., Nakhla, G. & Bassi, A. (2005). Electro-kinetic dewatering of oily sludges. *Journal of Hazardous Material*, Vol. B125, pp. 130-140.

11. Paczkowska, B. (2005). Electro-osmotic introduction of methacrylate polycations to dehydrate clayey soil. *Canadian Geotechnical Journal*, Vol. 42, pp. 780–786.
12. Fazeli, A., Habibagahi, G. & Ghahramani, A. (2009). Shear strength characteristics of Shiraz unsaturated silty clay. *Iranian Journal of Science and Technology, Transaction B, Engineering*, Vol. 33, No. B4, pp. 327-341.
13. Rahnema, A., Habibagahi, G. & Ghahramani, A. (2003). A new simple shear apparatus for testing unsaturated soils. *Iranian Journal of Science and Technology, Transaction B, Engineering*, Vol. 27, No. 1, pp. 73-80.
14. Chien, S.C., Ou, C.Y. & Hsieh, P.G. (2013). Application of electro-osmotic chemical treatment to improve soft clay in practice. *Proceedings of the Twenty-third International Offshore and Polar Engineering*, Anchorage, Alaska, USA, June 30-July 5, 2013.
15. Buckland, D. G., Shang, J. G. & Mohamedel Hassan, E. (2000). Electro-kinetic enhanced sedimentation of contaminated Welland River sediments. *Canadian Geotechnical Journal*, Vol. 37, No. 4, pp. 735-747.
16. Lo, K.Y., Micic, S., Shang, J.Q., Lee, N.Y. & Lee, S.W. (2000). Electrical strengthening of a marine sediment. *International Journal of Offshore and Polar Engineering, ISOPE*, Vol. 10, No. 2, pp. 137-144.
17. Sprute, R. H. & Kelsh, D. J. (1976). Dewatering and densification of coal waste by direct current laboratory tests. *United States Bureau of Mines Report*, No. 8197.
18. Larue, O., Wakeman, R., Tarleton, E. & Vorobiev, E. (2006). Pressure electro-osmotic dewatering with continuous removal of electrolysis products. *Chemical Engineering Science*, Vol. 61, pp. 4732–4740.
19. Reddy, K.R., Urbanek, A. & Khodadoust, A. P. (2006) Electro-osmotic dewatering of dredged sediments: bench-scale investigation. *Journal of Environmental Management*, Vol. 78, pp. 200–208.
20. Saveyn, H., Pauwels, G., Timmerman, R. & der Meeren, P. V. (2005). Effect of polyelectrolyte conditioning on the enhanced dewatering of activated sludge by application of an electric field during the expression phase. *Water Research*, Vol. 39, pp. 3012–3020.
21. McKinney, J. P. & Orazem, M. E. (2009). Electrokinetic methods for dewatering of phosphatic clay slurries. *ECS Transactions*, Vol. 19, No. 26, pp. 35–43.
22. Fourie, A. B., Johns, D. G. & Jones, C.J.F.P. (2007). Dewatering of mine tailings using electrokinetic geosynthetics. *Canadian Geotechnical Journal*, Vol. 44, pp. 160–172.
23. Shang, J. Q. (1997). Electrokinetic dewatering of clay slurries as engineered soil covers. *Canadian Geotechnical Journal*, Vol. 34, pp. 78–86.
24. El-Shall, H. & Zhang, P. (2004). Process for dewatering and utilization of mining wastes. *Mineral Engineering*, Vol. 17, pp. 269–277.
25. Ottosen, L. M. (2014). Electrokinetics in the removal of metal ions from soils. *Encyclopedia of Applied Electrochemistry*, DOI 10.1007/978-1-4419-6996-5_87, PP. 742-746.
26. Zhou, M., Zhu, S., Liu, Y. & Wang, H. (2014). Electrokinetic remediation of fluorine-contaminated soil using approaching cathodes. *Journal of CLEAN Soil Air Water*, Vol. 42, Issue 12, pp. 1771-1775.
27. Alcántara, M. T., Gómez, J., Pazon, M. & Sanromán, M. A. (2012). Electrokinetic remediation of lead and penanthrene polluted soils. *Geoderma*, Vol. 173–174, pp. 128–133.
28. Casagrande, L. (1949). Electro-osmosis in soils. *Geotechnique*, Vol. 1, No. 3, pp. 159-177.
29. Gray, D. H. & Mitchell, J. K. (1967). Fundamental aspects of electro-osmosis in soils. *Journal of Soil Mechanics and Foundation Engineering Division, ASCE*, Vol. 93, No. 6, pp. 178–205.
30. Casagrande, L. (1983). Stabilization of soils by means of electro-osmosis – State of the art. *Journal of Boston Society of Civil Engineers, ASCE*, Vol. 69, No. 2, pp. 255-302.
31. Mitchell, J. K. (1993). *Fundamentals of soil behaviour*. 2nd Edition, John Wiley and Sons Inc., New York.
32. Bjerrum, L., Moum, J. & Eide, O. (1967). Application of electro-osmosis to a foundation problem in a Norwegian quick clay. *Geotechnique*, Vol. 17, pp. 214-235.
33. Ozkan, S., Gale, R. J. & Seals, R. K. (1999). Electro-kinetic stabilization of kaolinite by injection of Al³⁺ and PO₄³⁻ ions. *Ground Improvement*, Vol. 3, pp. 135-144.

34. Shang, J. Q. & Lo, K. Y. (1997). Electro-kinetic dewatering of a phosphate clay. *Journal of Hazardous Materials*, Vol. 55, No. 1-3, pp. 117-133.
35. Mohammzadeh, K. (2012). Experimental investigation on the electro-osmotic method of consolidation of the Urmia Lake shoreline soft deposits. *M.Sc. Thesis*, Department of Civil Engineering, Urmia University, Urmia, Iran, p. 114 (In Persian).
36. Yeung, A. T. (1994). Electro-kinetic flow process in porous media and their applications. *Advances in Porous Media*, Vol. 2, pp. 307-393.
37. Esrig, M. I. (1968). Pore pressure, consolidation and electrokinetics. *Journal of the Soil Mechanics and Foundations Division*, Vol. 94, No. 4, pp. 899-921.
38. Darya-Khak-Pey Consulting Engineers (2005). Geotechnical investigation of Shahid Kalantari Highway in Salmas Bridge Junction in Km 20+60, Tehran, Iran (In Persian).